

CFSFL02

Intelligent addressable dual channel LON to fibre optic adapter

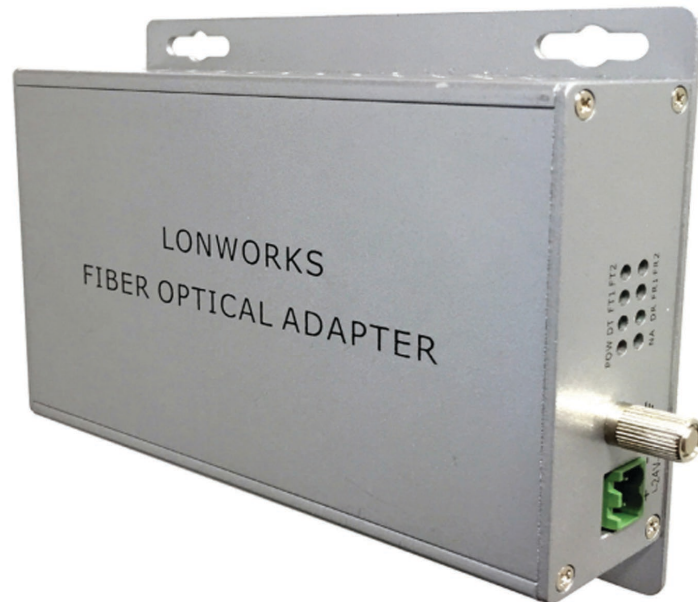

The dual channel LON to fibre optic adapter (CFSFL02) allows connection of Eaton's system network (LonWorks) devices through optical fibre, and to allow both point to point or multi drop topology.

Using only single-mode fibre optic, the CFSFL02 adapter allows extension of Eaton's system network LonWorks to a maximum distance of 15km with a transmission speed of up to 78Kbit/s or 1.25Mbit/s.

Connection is made using SC type fibre optic connectors. In comparison with conventional twisted pair cable, the fibre optic usage in a LonWorks network has many advantages; it is reliable and fast in long-distance network transmission even in difficult industrial environments (with transients, surges or electromagnetic interference etc.) without requiring any additional transient protection.

Features and benefits

- Simple to install, plug and play
- Easy to use
- Extends Eaton's panel network
- Fast response



Powering Business Worldwide

Technical Specification

Code	CFSFL02
Description	Dual channel LON to fibre optic adaptor
Specification	
Operating voltage	24V dc
Communication protocol	LonWorks
LonWorks connectors	Screw terminal block
LonWorks rate	78 Kbps / 1.25 Mbps
Bit error rate	10e-9
Wavelength	1310nm
Fibre type	Single mode fibre
Fibre diameter	9/125 micron
Fibre connector	SC type (optional ST type)
Link distance	15km
Environmental	
Operating temperature	-30°C to +70°C
Humidity (Non condensing)	20 to 90% RH
Physical	
Dimensions (H x W x D)	116mm x 136 mm x 34mm

Typical system architecture

Fibre Optic Point to Point Link

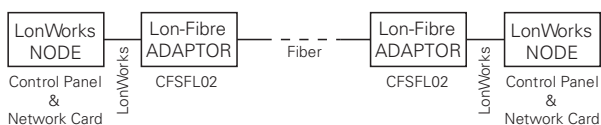

Fibre Optic Multi-Drop Link

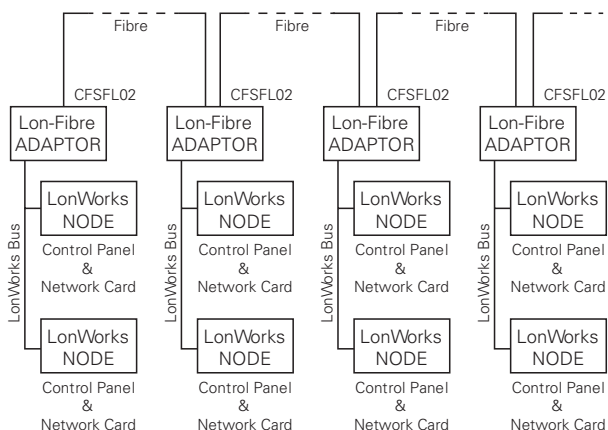

LED Indication

POW	Power on indication	'On' means power on
NA	Not Applicable	
DT	Fibre transmitting	'Flashing' means working
FT1	Fibre Port 1 transmitting data	'Flashing' means working
FR1	Fibre Port 1 Receiving data	'Flashing' means working
FT2	Fibre port 2 Transmitting data	'Flashing' means working
FR2	Fibre port 2 Receiving data	'Flashing' means working

Eaton
 EMEA Headquarters
 Route de la Longeraie 7
 1110 Morges, Switzerland
 Eaton.eu

© 2019 Eaton
 All Rights Reserved
 Publication No. TD-EN-1019
 October 2019

Dimensions

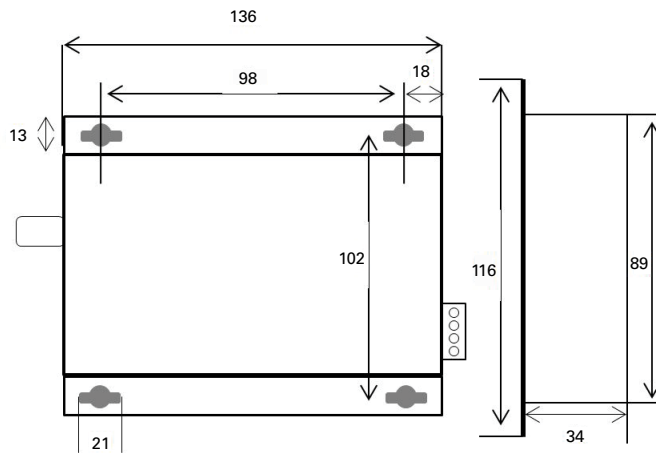

Measurements in MM

H (mm)	W (mm)	D (mm)
116	136	34

Installation

1. Ensure that the power supply is switched off during installation.
2. Take care when inserting the fibre optic connector to avoid damage.
3. Note:
 - a) FR1 should connect to the previous modules FT2
 - b) FT1 should connect to the previous modules FR2
 - c) FR2 should connect to the next modules FT1
 - d) FT2 should connect to the next modules FR1
4. LONA connects to Net_A of the Lonworks Bus (network card), LONB connects Net_B.

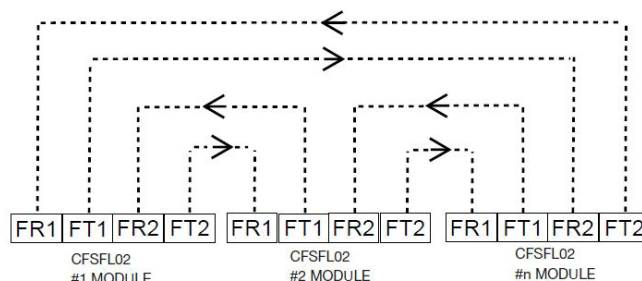

Mechanical layout and connections

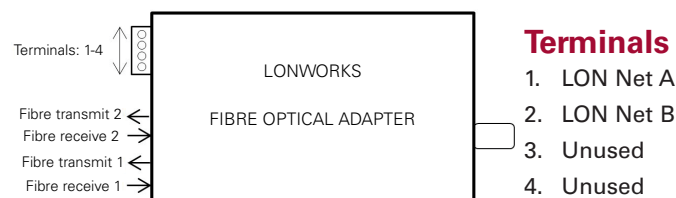

Terminals

1. LON Net A
2. LON Net B
3. Unused
4. Unused

Catalogue numbers

Description	Code
Dual channel LON to fibre optic adaptor	CFSFL02