

EC210L - Intelligent addressable dual-channel LonWorks BMS interface



The control panels on Eaton's Easichек network communicate using pre-configured network- variables and cannot normally be used with a BMS where binding is required.

The EC210L dual-channel LonWorks BMS interface is an "add-on" to the network which translates the pre-configured network variables to a set of un-configured network variables which can then be bound to a BMS, giving full access to the network data.

The gateway has 2 channels:

Channel 1 - connects to the Eaton Easichек network

Channel 2 - connects to the BMS

Features and benefits

- Allows Eaton's Easichек network to be controlled by a LonWorks enabled BMS
- Uses Echelon FT5000 smart transceivers for high noise immunity
- 32 message input buffer
- Compact DIN rail mounting enclosure
- Fully compatible with Eaton's Easichек network (no need for binding)
- Open protocol to 3rd party BMS system

Technical specification

Code	EC210L
Description	Dual-channel LonWorks BMS interface
Standards	CE compliant
Specification	
Supply voltage	12V dc to 30V dc
Supply current	< 30mA
Transceivers	Echelon FT5000 / FT-X1
Baudrate	78kbs
Connectors	5mm screw terminals
Physical	
Enclosure	ABS DIN rail mounting.
Dimensions (H x W x D)	86mm x 105mm x 58mm

Dimensions

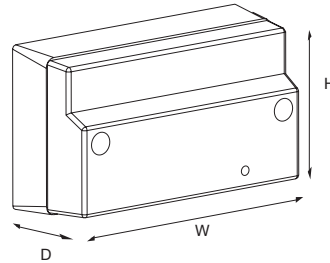

H (mm)	W (mm)	D (mm)
86	105	58

Typical system architecture

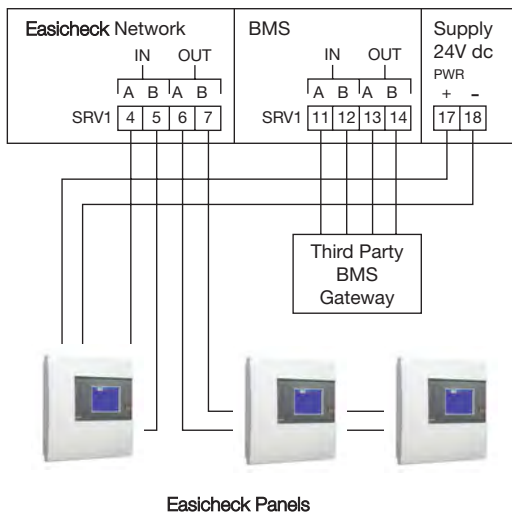

If the EC210L is located at the end of the system (spur) a 102Ω termination resistor must be fitted 1A, 1B.

Standard connections

PIN	Description
4	CHANNEL 1 A
5	CHANNEL 1 B
6	CHANNEL 1 A
7	CHANNEL 1 B
11	CHANNEL 2 A
12	CHANNEL 2 B
13	CHANNEL 2 A
14	CHANNEL 2 B
17	SUPPLY +
18	0V

Channel 1 - must be connected to Eaton's Easichck network
Channel 2 - must be connected to the BMS

Catalogue numbers

Description	Code
Dual-channel LonWorks BMS interface (self configuring for use with EC710)	EC210L