

Fire Systems Design Pocket Guide

BS 5839 Part 1:2017 and CoP 0001 for Visual Alarm Devices

Fire Installers Mate

A guide to fire system design



EATON

Powering Business Worldwide



We make what matters work.*

- * Every day, people depend on things like technology, transportation, energy and infrastructure to keep their daily lives on track. But without power, none of it would be possible. That's why companies around the world turn to Eaton. We're dedicated to improving people's lives and the environment with innovative technologies that help manage power more safely, reliably and sustainably. To meet today's challenges, and tomorrow's. Because this is what really matters. And we're here to make sure it works.

To learn more go to: Eaton.com/whatmatters

EATON

Powering Business Worldwide

We make what matters work.

Fire systems design

A guide to BS 5839 Part 1:2017 and CoP 0001 for Visual Alarm Devices (VADS)

Disclaimer

This booklet is not intended to be a comprehensive guide to all aspects of fire alarm design but rather a very useful source of background information.

Whilst every care has been taken to ensure that the contents of this document are correct at the time of publication, it should never be used as any form of substitution for the BS 5839 standard or CoP 0001 themselves. Eaton shall be under no liability whatsoever in respect to such contents.

It should be noted that there may be specific additional requirements dependent upon local authority building regulations and/or fire authority.

Please use this guide in conjunction with a current issue of BS 5839, CoP 0001 and other relevant CoP's or standards.

Contents

Section 1: Fire Systems Design - A guide to BS 5839 Part 1:2017

<i>Page</i>	<i>Subject</i>
4	Categorisation of Fire Alarm and Detection Systems
5	Loop System Short Circuit Isolators / Heat Devices
6	Cable Protection / Fire Resistant Cable for Critical Circuits
7	Zone Floor Areas
8	Zone Layout / Sounder Device Cabling
9-10	Sound Levels for Sounder Devices / Void Detector Coverage
11	Detector Ceiling Height Limits
12	Detector Coverage and Spacing
13	Detector Sensing Element Heights
14	Detector Obstructions
15	Detector Spacing Near Air Inlets / Stairways and Landings
16	Smoke Detectors in Corridors
17	Lift Shafts and Open Stairways / Callpoint Mounting
18	Callpoints in Escape Routes / Visual Alarm Mounting

Section 2: Visual Alarm Devices (VADs) and CoP 0001

<i>Page</i>	<i>Subject</i>
19	Introduction to VADs and CoP 0001 Overview
20	Ceiling Mounted Devices
21	Wall Mounted Devices
22	Open Class Devices
23	External Factors
24-25	General Rules for Selection and Siting
27	Coverage Distance Multiplication Factors
28	Power Supplies
29	Wiring
30-31	Installation and Commissioning
32	Maintenance
33-34	Lookup Tables for VAD Siting
35	Tools, Guides and References

BS 5839 Clause 5

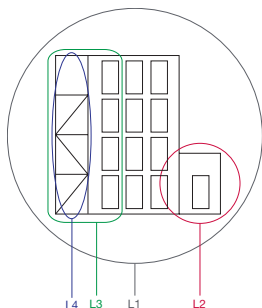
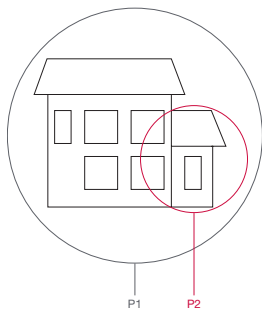

AFD - Automatic Fire Detection

Property Protection Fire Systems

- P** AFD designed to primarily protect property categories:
- P1** AFD installed throughout all areas
- P2** AFD installed only in defined areas

Life Protection Fire Systems

- L** AFD designed to primarily protect human life categories:
- L1** M plus AFD installed throughout all areas
- L2** AFD installed in defined areas of higher risk of ignition, in addition to L3
- L3** M plus AFD installed in escape routes and rooms opening into these routes
- L4** M plus AFD installed in escape routes comprising circulation areas and space such as corridors and stairways
- L5** A non-prescriptive system in which protected area(s) and/or the location of detectors is designed to satisfy a specific fire risk objective (other than that of L1 to L4)
- M** System designed to be operated manually (no AFD) with alarm devices (sounders/VADs throughout)

BS5839 Clause 12.2.2

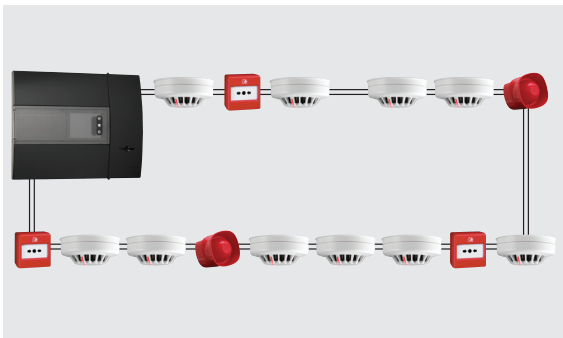

On a loop system, short circuit isolators are required to limit the effect of one fault to less than 2000m^2 floor area. Two simultaneous faults on a circuit should not disable protection within an area greater than $10,000\text{m}^2$.

BS5839 Clause 35.2.3

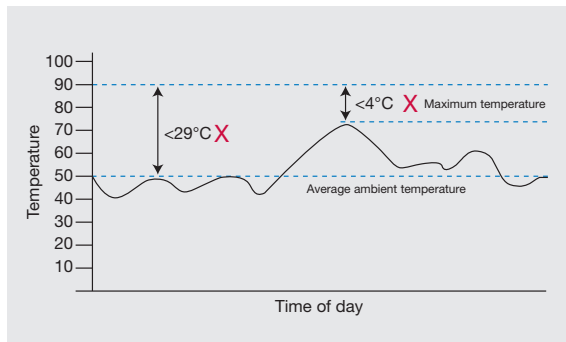

The minimum static response to heat devices should not be less than 29°C above the average ambient temperature, or less than 4°C above the highest temperature the device can be expected to experience.

BS5839 Clause 26.2h

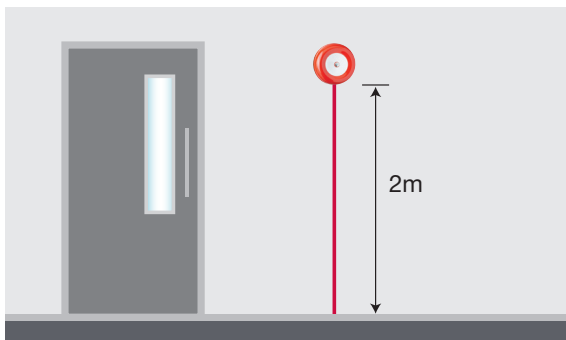

Unless MICC or armoured cable to BS7846 standard is used, consideration should be given to the protection against physical damage from floor level to the height of 2m. Except in relatively benign areas, such as shops, offices and similar, where cabling can be clipped to robust walls.

BS5839 Clause 26.2

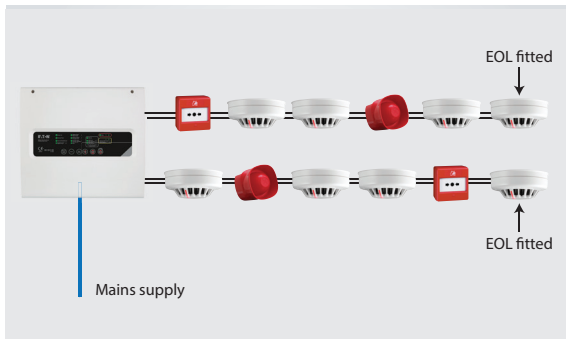

To comply with the current version of the BS 5839 Part 1, the use of fire resistant cables is required for all critical circuits, this includes detection, sounders and mains supply.

BS5839 Clause 13.2.3

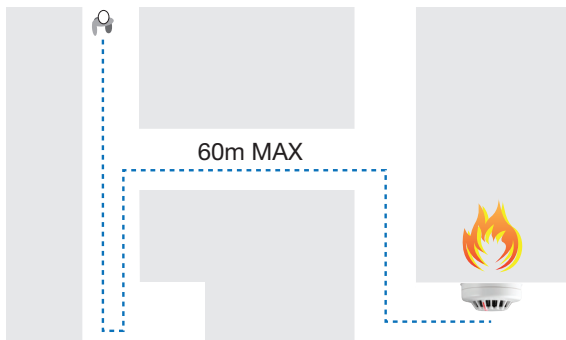

The maximum zone floor area should not exceed 2000m^2 . A person searching a zone for a fire should not have to travel more than 60m from the zone entrance to identify the source of the fire.

BS5839 Clause 13.2.1

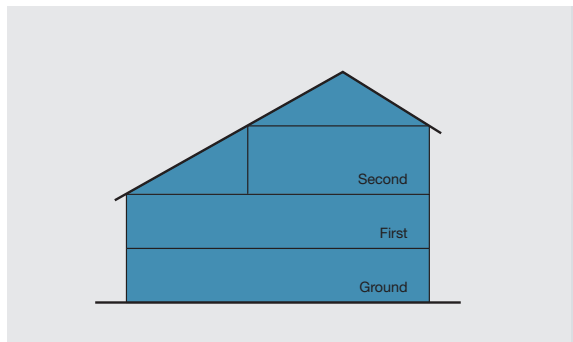

Less than 300m^2 can be covered by a single zone. When the total floor area exceeds 300m^2 , each floor would require a zone (or zones if the floor area exceeds 2000m^2). Stairwells, Liftwells or similar should be separate zones.

BS5839 Clause 13.2.1

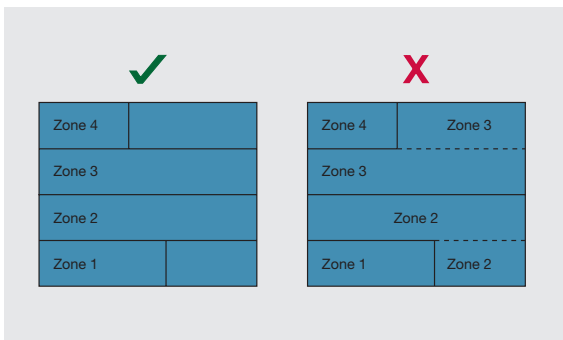

Zones should not cross floors.

BS5839 Clause 12.2.2

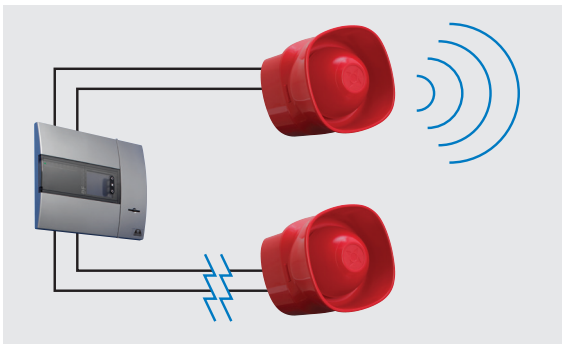

Sounder device cabling should be arranged so that in the event of a fault at least one sounder located within the vicinity of the control and indicating panel will remain in operation.

BS5839 Clause 16.2.1



The minimum sound level of a siren device should be **65dB(A)** or **5dB(A)** above a background noise that lasts more than 30 seconds and not less than 75dB(A) at the head of the bed if required to rouse people from sleep. The maximum sound level should not exceed **120dB(A)**.

BS5839 Clause 16.2.1

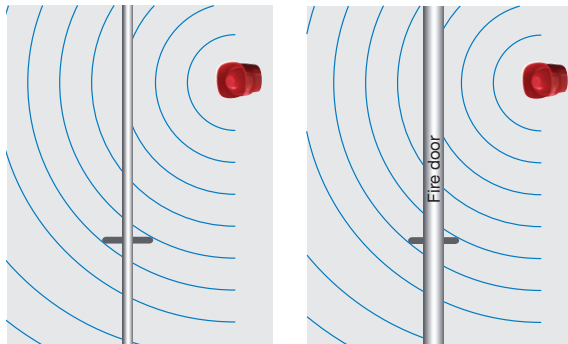

Decibel loss occurs through doors: Approximately **-20dB(A)** through a normal door, and approximately **-30dB(A)** through a fire door. **Unless a siren is installed in a bedroom, it is unlikely that 75dB(A) will be achieved.**

BS5839 Clause 16.2.1

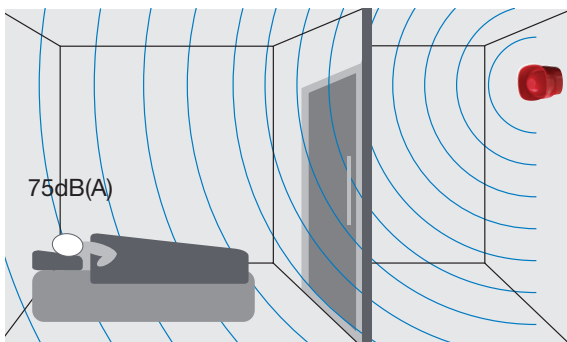

For areas where people are sleeping, sounder devices should produce a minimum **75dB(A)** at the bed-head with all doors shut. In buildings likely to provide sleeping accommodation for the hearing impaired, consideration should be given to the incorporation of both audio and visual devices.

BS5839 Clause 22.2d

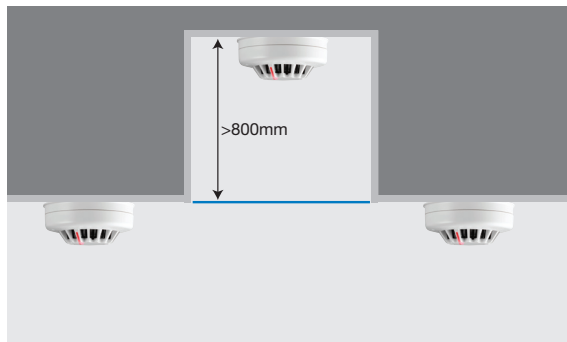

Voids less than **800mm** in height are required to have a risk assessment to determine if AFD is required. Voids in excess of **800mm** require independent coverage.

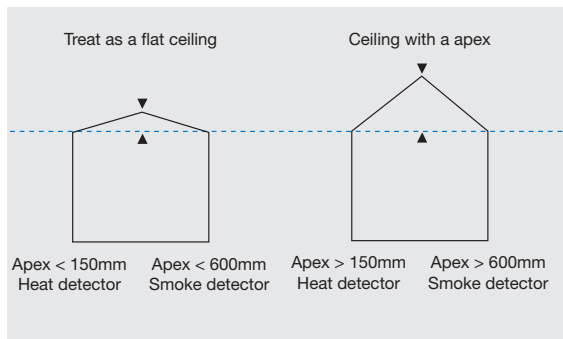

For ceilings that feature an apex: As long as the height of the apex from the rest of the ceiling is less than **150mm** for heat detectors or less than **600mm** for smoke detectors, then these can be treated the same as flat ceilings. For higher apices, a device should be installed at the highest point. The coverage of the device in the apex can be increased by **1%** per degree of angle of the roof up to a maximum of **25%**.

Detector Type	Maximum Ceiling Height (m)	
	General Limits	For 10% of Ceiling Area
Heat Detectors EN54-5		
Class A1	9.0	10.5
Other Classes	7.5	10.5
Point smoke and CO fire detectors	10.5	12.5
Aspirating smoke detection systems (category 1)		
General Limit	10.5	12.5
Class C (with 5+ holes)	15.0	18.0
Class C (with 15+ holes)	25.0	28.0
Class B (with 15+ holes)	40.0*	43.0*
Optical beam smoke detectors EN54-2		
Normal Sensitivity	25.0	28.0
Enhanced Sensitivity	40.0*	43.0*

*Refer to BS5839 Part 1 2017 for specific guidance

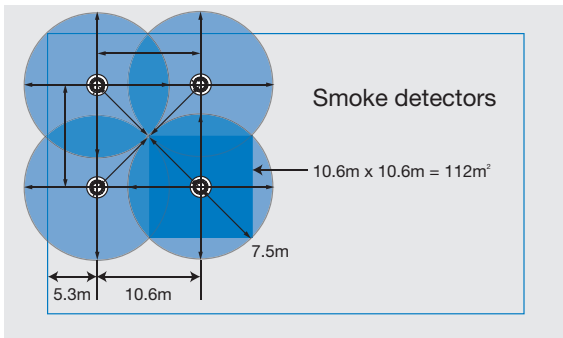

When mounted on a flat ceiling, smoke detection devices have an individual coverage of **7.5m** radius. However these radii must overlap to ensure there are no 'blind spots'. Therefore individual coverage can be represented by a square measuring **10.6 x 10.6m** giving an actual coverage area of **112m²** per device.

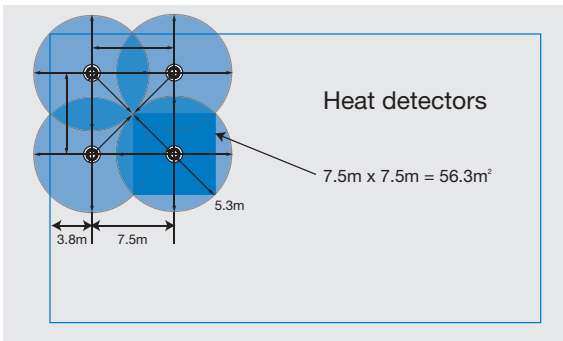

When mounted on a flat ceiling, heat detection devices have an individual coverage of **5.3m** radius. However these radii must overlap to ensure there are no 'blind spots'. Therefore individual coverage can be represented by a square measuring **7.5 x 7.5m** giving an actual coverage area of **56.3m²** per device.

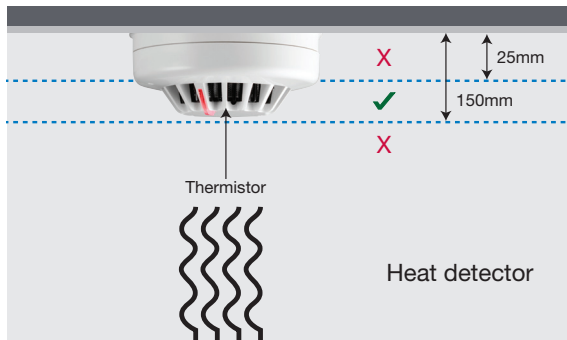

The sensing element of a heat detection device should not be less than 25mm below the ceiling, and not greater than 150mm below the ceiling.

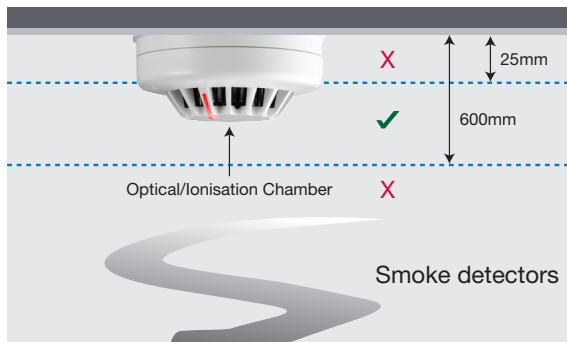

The sensing element of a smoke detection device (optical smoke chamber) should not be less than 25mm below the ceiling, and not greater than 600mm below the ceiling.

BS5839 Clause 22.3

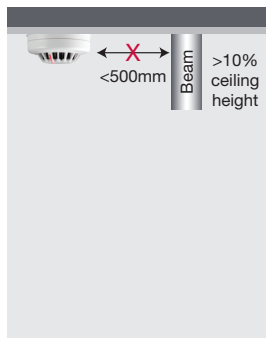
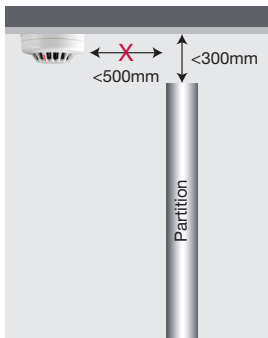

A device should not be mounted within **500mm** of any obstruction. If the top of a solid partition is less than **300mm** from the ceiling then it should be treated as a wall. Similarly, ceiling obstructions such as beams should be treated as walls if deeper than **10%** of the ceiling height (particularly important in voids).

BS5839 Clause 22.3

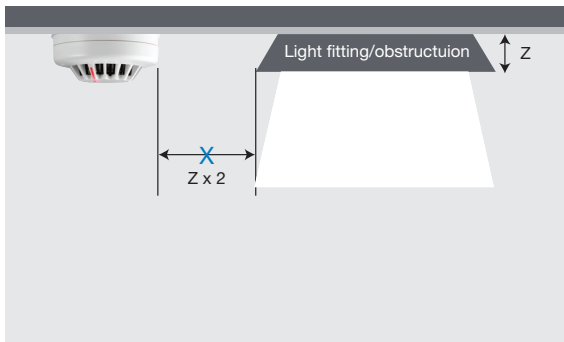

For obstructions less than **250mm** deep never mount devices closer than twice the depth of light fittings or other obstructions on the ceiling.

BS5839 Clause 22.3n

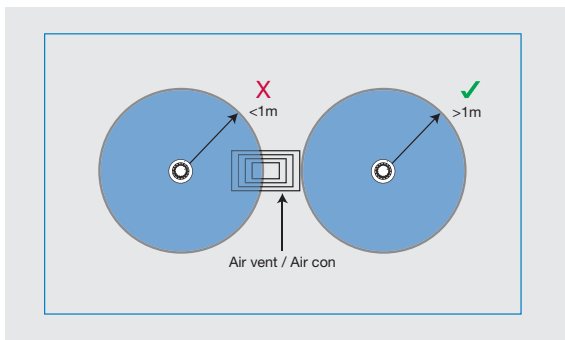

Do not site detectors less than **1m** from air inlets or air circulating systems.

BS5839 Clause 22.2b

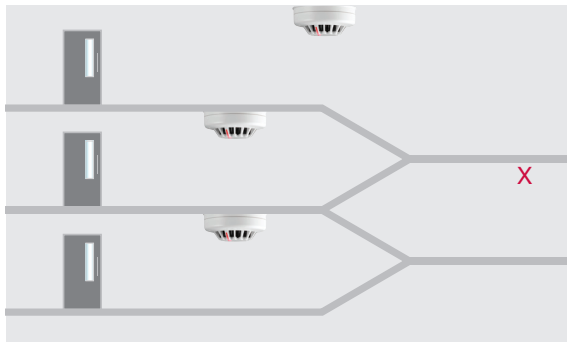

Enclosed stairways should have a detector on the **top** of the stairway and on each **main landing**.

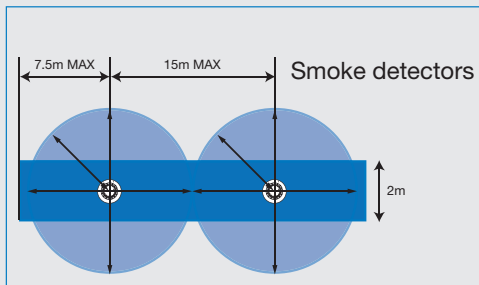

In corridors less than 2m wide the horizontal spacing of detectors can be increased, the area of coverage need not overlap as in the case of a room. Any corridor over 2m wide is deemed to be a room. Coverage should be provided as appropriate to system category.

Please note: Heat detectors are not recommended for use in corridors that may be used as escape routes.

For ease of design and assessment of coverage, dimensions used for detectors are usually taken as:

Smoke: 5m to wall / 10m between detectors
Coverage 100m²

Heat: 3.5m to wall / 7m between detectors
Coverage 50m²

BS5839 Clause 22.2c

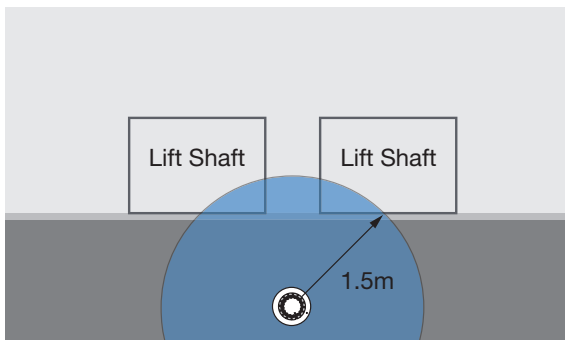

Vertical shafts, such as lift shafts and open stairways, should have a device mounted within **1.5m** of any opening.

BS5839 Clause 20.2h

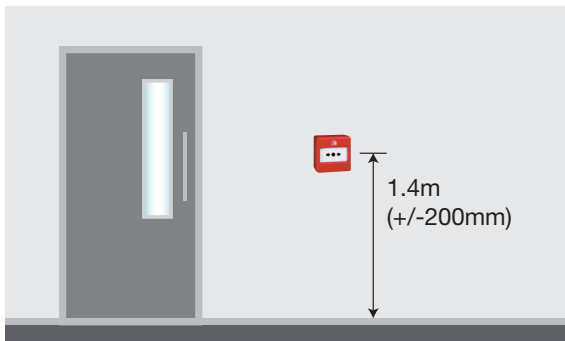

The centre of the element of the manual callpoint should be positioned **1.4m (+/-200mm)** from floor level (unless a wheelchair user is likely to be the first person to raise the alarm, when this is applicable it should be noted on any certification). All manual call points should be fitted with a protective cover, which is moved to gain access to the frangible element.

BS5839 Clause 20.2d

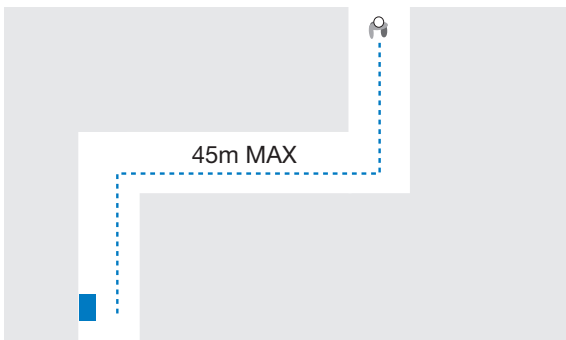

A person should not have to travel more than **45m** along an escape route to reach a manual callpoint, when the layout of the building is known.

BS5839 Clause 17.2f

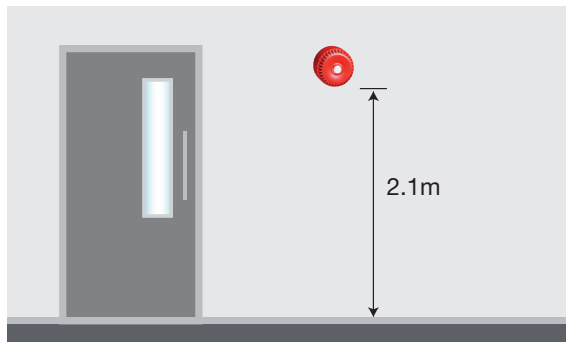

Visual alarms such as beacons should always be mounted at a minimum height of **2.1m** from floor level, in a position that is likely to attract attention.

Introduction to VADs (Visual Alarm Devices)

Visual Alarm Devices, or VADs, would generally be required where an audible alarm would not be effective or practical, or where further re-enforcement of the audible alarm is required.

Typical situations include: -

- Compliance with the Equality Act 2010 (UK only), local building regulations or related legislation
- Warning deaf or hard of hearing people of an emergency
- Areas of high ambient noise
- Staff restricted warning systems
e.g. : Nursing homes or hospitals;
Certain public assembly buildings
- Broadcast studios
- Hospital operating theatres



Overview of CoP 0001

CoP 0001 provides guidance and recommendations on the planning, design, installation, commissioning and maintenance of VADs.

- VADs assumed to conform to EN 54-23
- Complements BS5839-1, BS8300 and BS9999
- Use alongside building regulation and regional requirements
- VAD coverage volume clearly defined
- Required illumination is defined as 0.4 lux
- Common visual signal required throughout a building
- White or red flash allowed (for single stage alarm)



3 TopTip

Consider performing an on-site assessment or survey to review the best use and location for your VADs.

Ceiling Mounted Devices - C-x-y

C – Ceiling Mounted Device

CoP 0001 Clause 4.6.3

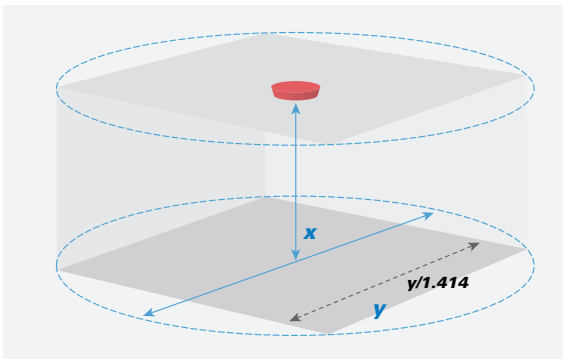

x – The maximum height of either 3, 6 or 9 m at which the VAD may be mounted

y – The diameter in metres of the cylindrical volume covered (to a minimum level of 0.4 lux) when the device is mounted to the ceiling at a height of 3, 6 or 9 m

Example:

C-3-15 corresponds to a ceiling-mounted device giving a coverage cylindrical volume of 15 m, when mounted at 3 m.

Note:

The protected space sits within the cylindrical volume and ensures that all areas meet the required illumination of 0.4 lux.

3 TopTip

To convert the coverage diameter **y** to the width of a square room
Width of square room = $y / 1.414$ m

Wall Mounted Devices - W-x-y

W – Wall Mounted Device

CoP 0001 Clause 4.6.3

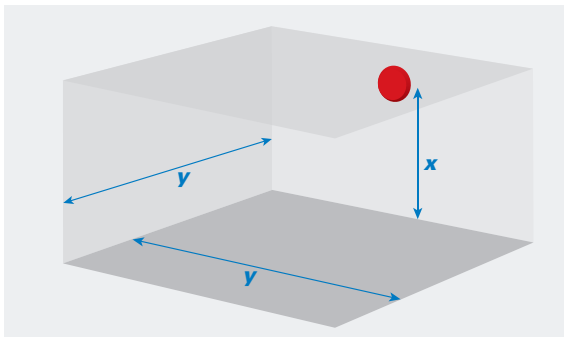

x – The maximum height of the device on the wall in metres, with a minimum value of 2.4m

y – The width in metres of the square volume covered (to a minimum level of 0.4 lux) when the device is mounted to the wall at a height **x**

Example:

W-2.4-7.5 corresponds to a wall-mounted device giving a coverage cuboid volume of 2.4m x 7.5m x 7.5m, when mounted at a height of 2.4m.

3 TopTip

- If the area to be covered is not square, use the larger of either the length or width to ensure that the whole area is covered.
- If the distance (**y**) measured above is greater than the VADs rated coverage, then several devices will be required to cover the area.

Open Class Devices

O – Open Class Device (coverage volume specified by manufacturer)

CoP 0001 Clause 4.6.3

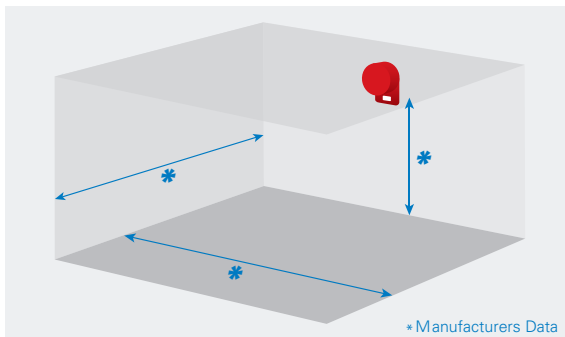

Open class devices do not conform to either the Wall or Ceiling category. However, they still need to meet the required illumination of 0.4 lux over their specified range.

Manufacturer's specification will include: -

- The mounting position
- The mounting orientation
- The minimum and maximum mounting height
- The shape, dimensions and orientation of the coverage volume (0.4 lux)

Example:

O-Corridor VAD

Mounting position - centre of wall at end of corridor as shown above

Orientation - with beacon at base of unit

Mounting Height = 2.0 – 3.0 m

Coverage volume – 0.4 lux polar dispersion data issued by manufacturer

External Factors

External factors, such as ambient light levels or the environment can have a significant influence on the effectiveness of VADs. It is important to consider what effect these external factors may have.

CoP 0001 Clause 4.6.4 – 4.6.8

Main consideration factors:

- **Ambient light level**
Will artificial light and natural light be a factor (time of day, etc)
- **Reflective surfaces**
Are walls or other surfaces matte or shiny, etc.?
- **Field of view**
Is the light visible from the VAD 'directly' or 'indirectly'
e.g. light reflected from an adjacent surface would be indirect
- **Use of tinted eye protection**
Is the VAD to be used in an industrial environment, where personal protective equipment (PPE) may be in use, etc.?
- **The environment**
Indoor Type A devices – IP21C, Outdoor Type B devices – IP33C

IP (Ingress Protection) ratings

Eaton's fire products may have higher IP ratings than that required by EN 54-23. This can offer a device that is more flexible for a wider range of applications or uses beyond standard practice.

IP ratings – Good Practice

- Use a higher IP rating, if the device is to be used in high humidity or damp conditions
- Use suitable cable glands to maintain the specified IP rating
- Ensure the correct product orientation
- Ensure all base and mounting screws, or fixings are secure

Please consult the relevant Installation Guide, Product Manual and our website for further details on specific products.

3 TopTip

You may need to perform an on-site assessment or survey to assess the ambient light levels, environmental conditions and other relevant factors. A lux meter complying with BS667 will be needed to assess ambient light levels.

General rules for selection and siting

- **Wall mounted VADs are likely to be effective in a wide range of applications**
 - Suitable for higher ambient light levels and the preferred choice for general applications
- **Ceiling mounted VADs are suitable for broad coverage in regular shaped rooms**
 - However, they are more likely to be affected by higher ambient light levels
 - Can be used as an alternative to wall mounted devices and are more practical to install in large open areas
- **Open category VADs should take into account manufacturer's recommendations**
 - Care should be taken that minimum illumination level of 0.4 lux is met throughout the area
- **Applications where there is continuous surveillance of a VAD in a specific direction, may not require widespread coverage**
 - A seated auditorium or a broadcast studio may only require limited coverage
- **Where possible, site the VADs for direct viewing for all occupants in an area**
 - If this is not possible, consider the minimum illumination on adjacent reflected surfaces
- **If relying on indirect illumination, the reflecting surfaces should be within the coverage area of the VAD**
 - The 'coverage area' is that stated for the VAD, multiplied by the coverage distance multiplication factors in the table on page 11
 - The indirect illumination may be reduced if a formal assessment determines negligible risk
- **Where an area to be covered is larger than the coverage area of a single VAD, a sufficient number of extra VADs should be sited appropriately**
 - Applies particularly to hotel bedrooms and bathrooms
 - Also applies to people wearing ear defenders or where they may be working alone or focusing on specific activity

General rules for selection and siting

CoP 0001 Clause 4.6.9.2

- Dependence on direct line of site should not be relied upon, if the VAD is used where deaf or hard-of-hearing people may be alone for prolonged periods
- Before selecting a VAD for a specific area, the ambient light level should be determined
 - Ambient level should be the maximum anticipated at any time
 - The ambient light level may be reduced by measures such as blinds or curtains on windows
 - Consult the building designer when selecting VADs at the planning stage of a new build
 - A lux meter complying with BS 667 should be used to determine the average ambient light levels (see CoP 0001 4.6.9.2. j)
- In the case of stairwells, the illumination from a VAD should satisfy the recommendations of this CoP across the area of each landing
 - Compliance may not be necessary throughout the stairway



Coverage Distance Multiplication Factors

Multiplication factors should only be used after careful consideration of the application, including prevailing ambient light level and the need to rely on indirect, rather than direct illumination.



Table 1 gives multiplication factors that can be applied to the coverage distance for VADs certified to EN 54-23. These may increase, or decrease the specified coverage volume stated by the manufacturer of the device.

Table 1. Coverage Distance Multiplication Factors

Ambient light level (lux)	Ceiling mount direct view	Ceiling mount indirect view	Wall mount direct view	Wall mount indirect view
<100	2.8	1.3	5.2	1.8
100 to 200	2.4	1.2	4.4	1.7
200 to 300	1.9	1.0	3.2	1.4
300 to 400	1.4	0.8	2.3	1.2* see below
400 to 500	1.1	0.6	1.8	1.0
500 to 600	0.9	0.5	1.3	0.9
600 to 700	0.7	0.4	1.0	0.7
700 to 800	0.5	0.3	0.7	0.6

CoP 0001 Clause 4.6.9.3

Example:

A wall mounted VAD with a rating W-2.4-7.5 is to be used in a location where the ambient light level is 350 lux and the view is considered to be indirect.

From the table, multiply the rated coverage distance of 7.5m, by the factor 1.2*. The mounting height may also be multiplied by 1.2*.

This gives a final coverage of $7.5 \times 1.2 = 9$ m mounted up to a height of $2.4 \times 1.2 = 2.88$ m

The VAD can therefore be used in this location, as if it were rated W-2.88-9

3 TopTip

It is sometimes better to try and control the light level in a room, rather than design a solution for a room bathed in direct sun light.

Power Supplies

CoP 0001 Clause 4.7

Power supplies should be compliant with BS EN 54-4 and the recommendations of BS5839-1. In particular, the following points apply:

- Both the normal and standby supply should each be independently capable of supplying the maximum alarm load imposed by the system, irrespective of the condition of the other supply
 - High peak loads which may be imposed by VADs should be taken into account
- The high peak power requirements of any VAD connected to a system should have no effect on any other function
- Manufacturers of VADs and power supply equipment should make available sufficient information to allow the compatibility of power supplies to be assessed
- Data should be available on request (see below)

Power supplies with larger installations - example

- Power supply should be capable of providing a current of at least $1.2 \times$ total VAD operating current
- Power supply surge capability should be at least $1.5 \times$ the total VAD surge current for at least 10mS
- A suitable slow-blow fuse must be fitted to the output stage of all power supplies
- Where a large number of units are to be wired, it is recommended to use multiple power supplies on separate spurs to avoid large voltage drops that would otherwise be encountered. See below:

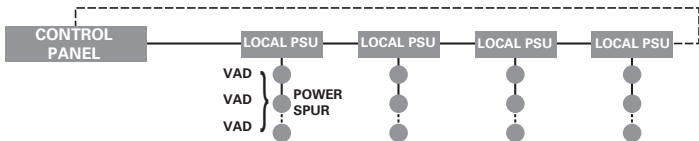

3 TopTip

Our product manuals give practical advice on what to consider when specifying power supplies for a VAD based system. The relevant product manual is referenced on the Installation Guide with each product and can be accessed via our website.

Wiring

CoP 0001 Clause 4.8

Cables serving VADs should conform to the recommendations of BS 5839-1 clause 26.2

- ... to ensure that cables used in circuits of VADs remain operational for an adequate duration, cables with an inherent ability to resist attack by fire need to be used

Cable resistance and run length - example

It is important that the series resistance (R_s) of a given cable is known, as this can have a significant effect on the on the maximum length of cable run possible.

The following table gives an indication of the cable lengths that could be used with a typical setup and is based on solid core wire with a cross sectional area (CSA) of 1.0mm^2 . If using a different CSA, cable type or a material other than copper, the value of the series resistance of the cable (R_s) will change significantly and will need to be factored into the calculations accordingly.

Please note that that all devices are assumed to be wired to the end of a spur, as this is the worst case scenario.

Typical Wiring Calculations (Solista LX Wall) for example purposes ONLY

Number of products (N)	Typical max current consumption of product (Is) - Amps	Typical power supply steady state capability (Ip) - Amps	Max cable resistance for 10% voltage drop @ 18Vdc (Rc) - ohms	Max cable length for 10% voltage drop @11.18Vdc (L) - Meters
1	0.15	0.18	12	333
2	0.30	0.36	6	167
3	0.45	0.54	4	111
4	0.60	0.72	3	83
5	0.75	0.90	2.4	66

* Note: Cable is assumed to be copper, with a resistance of $1.8\Omega/100\text{m}$. All calculations and advice is given for guidance ONLY. No liability is assumed for the use of these calculations or advice, or for any errors or omissions. The installer is responsible for ensuring that the product is installed and wired correctly and safely using all relevant and current wiring regulations and practices.

3 TopTip

If longer cable runs are required than those given in the example above, larger gauge cables should be specified to reduce the effects of the cable resistance.

Installation and Commissioning

CoP 0001 Clause 5.1

Responsibility of installer

- Consult with all relevant parties
- This may include user or purchaser, designer, VAD supplier, architects, fire consultants, etc.
- Report and document any variations not already identified (usually noted on the design certificate)
- Separate all metallic parts of the installation from any metalwork forming part of lightning protection
- Include VADs in any “as fitted” drawings, if this is down to the installer
- Ensure mains supplies comply with BS5839-1 Clause 25.3 and 25.4
- Supply separate electrical installation certificates (BS7671) for any separate mains supplies powering VADs
- Sign an installation certificate of the type recommended in BS5839-1, Annex G2

CoP 0001 Clause 5.2 & 5.3

Installation Practices and Workmanship (inc. Inspection and Testing of Wiring)

- Installation should comply with BS5839-1 Clause 37.1 and 37.2
- To achieve the correct light coverage, follow the VAD manufacturer’s recommendations
 - This will include correct mounting height and orientation to achieve the required illumination
- Mounting bases with suitable ingress protection (IP ratings) should be selected for the location
- VADs should be sited so that they do not form a protrusion hazard
- Wiring should be inspected and tested in accordance with BS5839-1 Clause 38.1 and 38.2

Installation and Commissioning (continued)

CoP 0001 Clause 6

Commissioning should be carried out in accordance with BS5839-1 Clause 5, in addition:

- The position and ratings of VADs should comply with CoP 0001 4.6.9 and system design drawings
- All VADs used for indication of a fire alarm should produce the same colour flash within the building
- VADs must not be confused with any other visual alarm signal within the building
- Where multiple VADs are visible from any single point, they should meet the synchronisation requirements of CoP 0001 Clause 4.3.6.2 (f) and 4.5.4
- Documentation should include “as fitted” drawings showing location and light output ratings of all VADs, in addition to any documents or certificates required by BS5839-1

3 TopTip

It may be wise to mark up any site plans or drawings with VAD locations and settings as they are commissioned. This may save time and effort later.



Maintenance

CoP 0001 Clause 7.1

Documentation

- BS 5839-1 recommends that fire detection and alarm systems are tested weekly
 - This can provide an opportunity for occupants to report any instances of poor visibility or non-operation
- Instructions to occupants should be to note any instances of poor visibility and report
 - This also provides an opportunity for occupants to become familiar with the VAD signals
- Staged systems with a separate alert and alarm, should have both states tested
 - Where practical, stages should be activated sequentially in the order that they would occur at the time of a fire (i.e. 'Alert' then 'Evacuate')

CoP 0001 Clause 7.2 & 7.3

Inspection and Servicing (inc. non-routine attention)

- Inspection and servicing of equipment and, including circuits serving VADs and the VADs themselves, should comply with BS 5839-1 Clause 45
 - The correct operation of all circuits serving VADs should be confirmed at this time
- The operation, and where applicable, the synchronisation of each VAD should be checked annually as a minimum
 - The lens should be cleaned to remove any dirt or deposits (where necessary)
 - Confirm that the VADs are not obstructed from view
- Non routine attention should be carried out in accordance with BS 5839-1 Clause 46
 - VADs no longer providing adequate coverage should be identified to the responsible person appointed by the user
 - After any fire, affected VADs and circuits should be inspected /tested. VADs should be checked and cleaned of any soot or other deposits

3 TopTip

Regular inspection, servicing and maintenance of VAD systems is important to help ensure the integrity and performance of the system.

Lookup tables for VAD siting

(pre-determined design)

There are two alternative approaches to the design of VAD installations. The first is a “pre-determined approach” which may be used for rooms of simple geometry and specified size. In this case, the tables below gives look-up values that can be used with frequently encountered ambient illumination.

The second approach is the “application specific solution”, which can be used in any application but is essential in more complex situations that are outside the scope of this section and this guide.

See CoP 0001 4.6.2 for further details.

Minimum ratings for ceiling-mounted devices in square rooms

Maximum room size (m)	VAD mounting height (m)	Uncorrected EN54-23 VAD rating minimum requirement (e.g. C-x-y)
2 x 2	3	C-3-2.8
3 x 3		C-3-4.2
4 x 4		C-3-5.6
5 x 5		C-3-7.0
10 x 10		C-3-14.0

Minimum ratings for ceiling-mounted devices in corridors, mounted at the mid-point

Maximum room size (m)	VAD mounting height (m)	Uncorrected EN54-23 VAD rating minimum requirement (e.g. C-x-y)
3 x 1.5	3	C-3-3.4
4 x 1.5		C-3-4.3
5 x 1.5		C-3-5.2
7 x 1.5		C-3-7.2
15 x 1.5		C-3-15.0
3 x 2	3	C-3-3.6
4 x 2		C-3-4.5
5 x 2		C-3-5.4
7 x 2		C-3-7.3
14 x 2		C-3-14.1
3 x 2.5	3	C-3-3.9
4 x 2.5		C-3-4.7
5 x 2.5		C-3-5.6
7 x 2.5		C-3-7.4
10 x 2.5		C-3-15.3

Lookup tables for VAD siting (continued)

Minimum ratings for wall-mounted VADs at height 2.4m in square and oblong rooms

Maximum room size (m)	VAD mounting height (m)	Uncorrected EN54-23 VAD rating minimum requirement (e.g. C-x-y)
3 x 3	1a)	W-2.4-3
4 x 4		W-2.4-4
5 x 5		W-2.4-5
7 x 7.5		W-2.4-7.5
4 x 2	2b)	W-2.4-2
8 x 4		W-2.4-4
10 x 5		W-2.4-5
15 x 7.5		W-2.4-7.5
4 x 4	4c)	W-2.4-2
6 x 6		W-2.4-3
10 x 10		W-2.4-5
15 x 15		W-2.4-7.5

- a) When using one VAD in a square, or nearly square space, the device should be mounted at the half-way distance of the longest wall.
- b) When using two VADs in an oblong space, the space should be subdivided into two approximately square spaces and the devices should be mounted at the half-way distance of the longest wall in each space.
- c) When using four VADs in a large space, the space should be subdivided in four approximately square spaces and the devices should be mounted at the half-way distance of the longest wall in each space.

Minimum ratings for wall-mounted VADs at height 2.4m in corridors

Maximum room size (m)	VAD mounting height (m)	Uncorrected EN54-23 VAD rating minimum requirement (e.g. C-x-y)
3 x 2	1a)	W-2.4-3
4 x 2		W-2.4-4
5 x 2		W-2.4-5
7 x 2		W-2.4-7.5
4 x 2.5	2b)	W-2.4-2
8 x 2.5		W-2.4-4
10 x 2.5		W-2.4-5
15 x 2.5		W-2.4-7.5

- a) When using one VAD to cover the length of a corridor, the device should be sited at the half-way distance, or at the centre of either end.
- b) When using two VADs to cover the length of a corridor, the devices should be sited at a quarter of the corridor distance from both ends, or in the centre of either end.

Tools, Guides and References

VADs Online Specification Tool

www.CooperFire.com

Specification Design Templates

FireTechSupport@eaton.com

Download Product Datasheets and Brochures

www.uk.eaton.com

Fire Product Support

FireTechSupport@eaton.com

References, Official Standards and Codes of Practice

CoP 0001 - www.fia.uk.com

BS5839-1, BS8300, BS9999 – www.bsi-global.com

EN 54-23 – www.bsi-global.com

Eaton Electrical Systems Ltd

Wheatley Hall Road
Doncaster
South Yorkshire
DN2 4NB
United Kingdom

www.uk.eaton.com

Sales

T: +44 (0)1633 628 566

F: +44 (0)1302 367 155

E: FireCustomerService@eaton.com

Technical and Quotations

T: +44 (0)1302 303 350

F: +44 (0)1302 303 340

E: FireTechSupport@eaton.com

Service

T: +44 (0)1302 303 352

F: +44 (0)1302 303 332

E: FireService@eaton.com

Export

T: +44 (0)1302 303 344

F: +44 (0)1302 303 345

E: FireExport@eaton.com

Disclaimer

This booklet is not intended to be a comprehensive guide to all aspects of system installations, but rather a useful source of background information.

Whilst every care has been taken to ensure that the contents of this document are correct at the time of publication, it should never be used as any form of substitution for the current issues of CoP 0001, BS 5839, or any other regulatory or legislative documents. Eaton shall be under no liability whatsoever in respect to such contents.

It should be noted that there may be specific additional requirements that may need to be taken into account, dependent upon local authority building regulations, fire authority and/or building risk assessment.

Please use this guide in conjunction with CoP 0001, BS5839 and other relevant CoPs or applicable standards.

Eaton is dedicated to ensuring that reliable, efficient and safe power is available when it's needed most. With unparalleled knowledge of electrical power management across industries, experts at Eaton deliver customized, integrated solutions to solve our customers' most critical challenges.

Our focus is on delivering the right solution for the application. But, decision makers demand more than just innovative products. They turn to Eaton for an unwavering commitment to personal support that makes customer success a top priority.

For more information, visit www.uk.eaton.com

Eaton

Electrical Sector EMEA
Route de la Longeraie 7
1110 Morges, Switzerland

Eaton Electrical Systems Ltd

Wheatley Hall Road
Doncaster
South Yorkshire
DN2 4NB
United Kingdom
www.uk.eaton.com



Powering Business Worldwide

© 2018 Eaton
All rights reserved
Printed in the UK
Publication Reference: PA-EN-450-0118