

# Contents

<b>1. INTRODUCTION</b> .....	<b>1</b>
<b>2. OVERVIEW</b> .....	<b>1</b>
<b>3. PC SOFTWARE OPERATION (SITE INSTALLER)</b> .....	<b>2</b>
<b>4. FAN CONTROLLER OPERATION</b> .....	<b>4</b>
4.1 OPERATION PROCESS .....	<b>4</b>
4.1.1. MANUAL/AUTO KEY SWITCH .....	<b>4</b>
4.1.2. KEY SWITCH IN "MANUAL" .....	<b>4</b>
4.1.3. KEY SWITCH IN "AUTO" .....	<b>4</b>
4.1.4. FAULT MONITORING .....	<b>4</b>
4.1.5. RESET .....	<b>4</b>
4.1.6. TEST LED .....	<b>4</b>
<b>5. BASIC SYSTEM LAYOUT</b> .....	<b>5</b>
5.1. FC18 AND CFC301 ON SAME PANEL AND LOOP .....	<b>5</b>
5.2. FC18 AND CFC301 ON SAME PANEL BUT DIFFERENT LOOPS .....	<b>5</b>
5.3. FC18 AND CFC301 ON DIFFERENT NETWORKED PANELS .....	<b>5</b>
5.4. FC18 AND MCOM/MCIM ON SAME PANEL AND LOOP .....	<b>5</b>
5.5. FC18 AND MCOM/MCIM ON SAME PANEL BUT DIFFERENT LOOPS .....	<b>6</b>
5.6. FC18 AND MCOM/MCIM ON DIFFERENT NETWORKED PANELS .....	<b>6</b>
<b>6. FC6 SPECIFICATION</b> .....	<b>7</b>
6.1. ELECTRICAL SPECIFICATIONS .....	<b>7</b>
6.2. MECHANICAL SPECIFICATIONS .....	<b>7</b>

## 1. Introduction

- The FC18 Fan Controller can be connected to a Cooper analogue addressable fire alarm control panel by means of the comms Loop utilizing only one address.
- There are 6 channels per Fan Controller capable of controlling & indicating 6 individual Fans.
- All FC18 Fan Controllers are programmed individually by means of the unique easy to use Cooper Site Installer PC software.
- Each channel is programmed to an output device and feedback input device that can reside on any loop on any panel on the network to control & monitor the status of the Fan.
- The CFC301 which takes 2 addresses on the loop, one for the control output which appears as a ZMU and one for the feedback input which appears as a technical input.
- The MCIM can also be used as the feedback input.
- The MCOM can also be used as the control output but is limited to 20 per loop.
- The MCOM-S can also be used as the control output and is limited to 60 per loop but as it auto-learns and behaves like a sounder it will activate during an evacuation.
- The MCOM-FC can also be used as the control output and is limited to 60 per loop but even though it auto-learns as a sounder it will not react to evacuations.

## 2. Overview

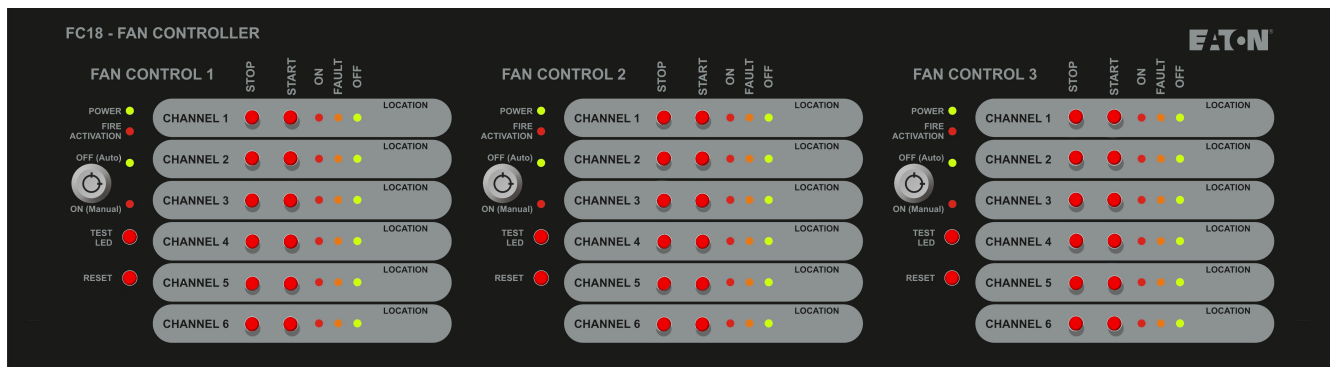

### Status LED

- Power LED (Green) when Fan Control is working normally, the LED on
- Fire Activation LED (Red) Operates when fire alarm is received from main panel

### Controls:

#### Key switch

- Auto/Manual key switch: used to select auto or manual control
- Select Auto Mode: Green LED. The Fan Control operation is initiated by the state of the Fire Panel
- Select Manual Mode: Red LED, The Fan Control operation is controlled by the "Stop/Start" buttons on the individual channels

#### Reset button

- Press the button to reset Fan Control. Reset from the main panel will not reset the fan controller

#### Test LED

- Pressing the test LED button will start the control panel self-test

### Channel 1-6:

#### Start/stop buttons

- Start button: press the button, start one device. (Requires to start two channels of the one device)
- Stop button: press the button to stop one device. (Requires to stop two channels of the one device)

#### LED indication

- ON LED (Red) Activated when the device receives feedback and the Start button has been pressed, otherwise, off.
- Fault LED (Amber) Activated when No Feedback has been received after Start has been pressed or Stop button has been pressed but feedback has been received and/or Open Circuit/Short circuit has been reported, otherwise off.
- OFF LED (Green) Activated when the stop button has been pressed and No Feedback has been received or no feedback is being received, otherwise off.

### 3. PC software operation (Site installer)

1. Start "Site Installer" program.

**Figure 1.**



2. Right click Fan Controller icon (Figure 2).

**Figure 2.**



Fan controller icon

3. Select "Edit Fan Controller" to go into the configuration screen.

**Figure 3.**



4. Once in the configuration screen Select "Add Master"

**Figure 4.**

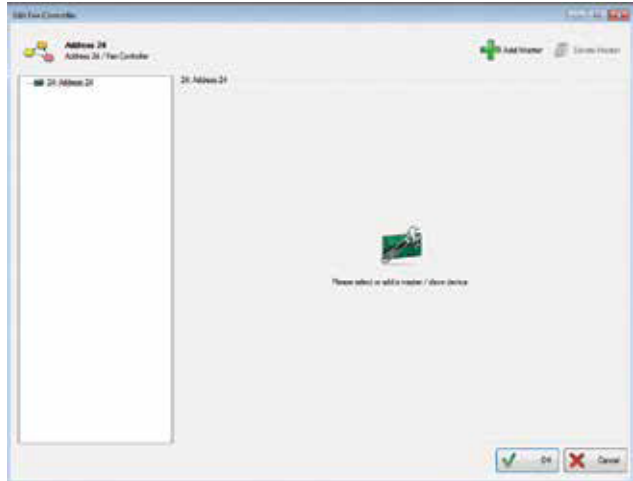

**Figure 5.**

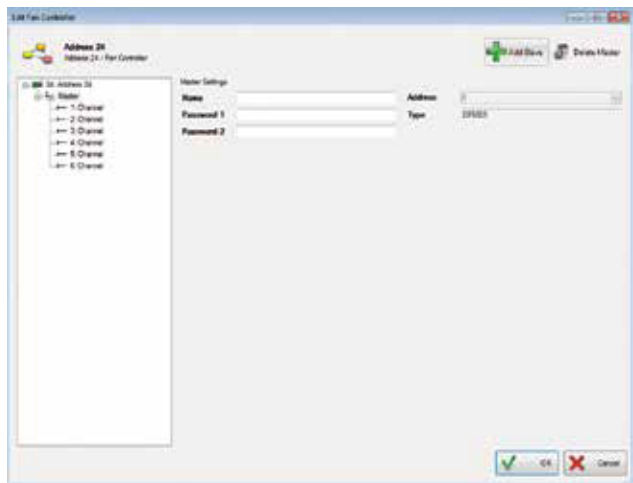

5. Select the output channel, one to six in the configuration screen

Select the "Enabled" in the configuration screen  
 Select the "Loop Mode" in the configuration screen  
 Select the "Confirm" in the configuration screen

**Figure 6.**

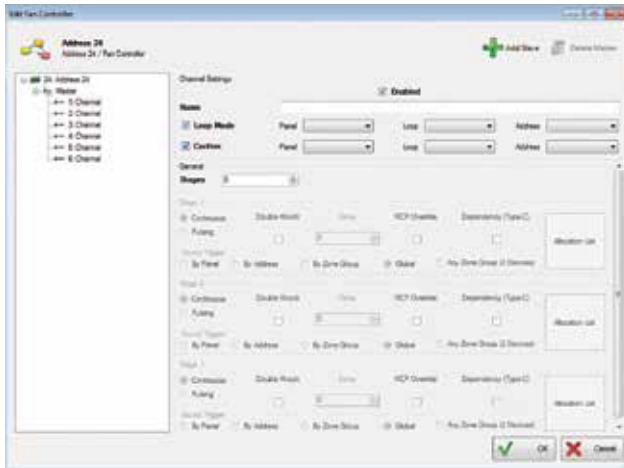

In the Panel, Loop and Address icons (drop down boxes) across from the Loop Mode, select where the control device you are going to use (CFC301 ZMU, MCOM, MCOM-S, MCOM-FC) is located on the system.

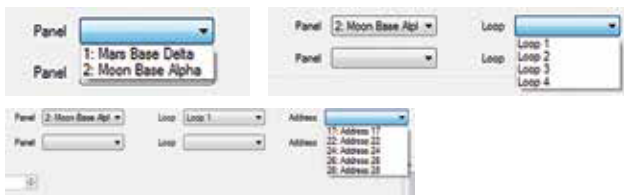

In the Panel, Loop and Address icons (drop down boxes) across from the Confirm, select where the feedback device you are going to use (CFC301 Technical Input, MCIM) is located on the system. This only needs to be set if there is feedback from the fan itself.

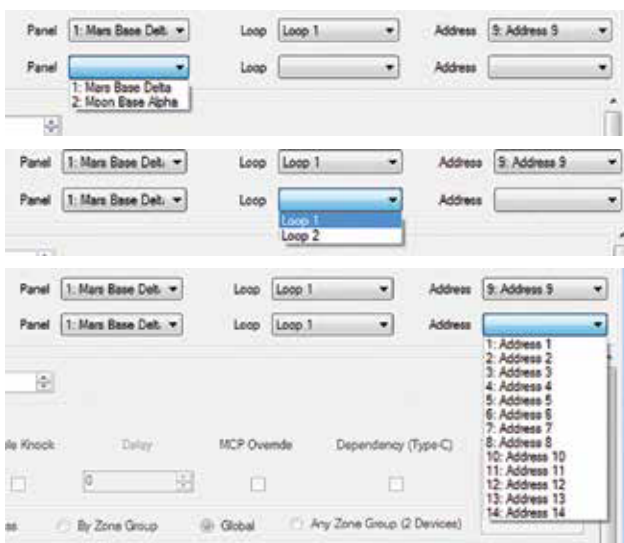

If you use 6 channels, you need to open the 6 channels which will allow you to write 6 rules.

6. Select in the configuration screen which cause and effect is needed for the output to activate.

**Figure 7.**



Global

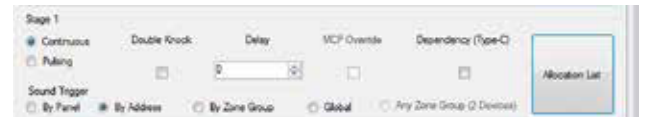

By address



By zone group

Select up to 3 stages to have a combination of different cause and effect results.

**Figure 8.**

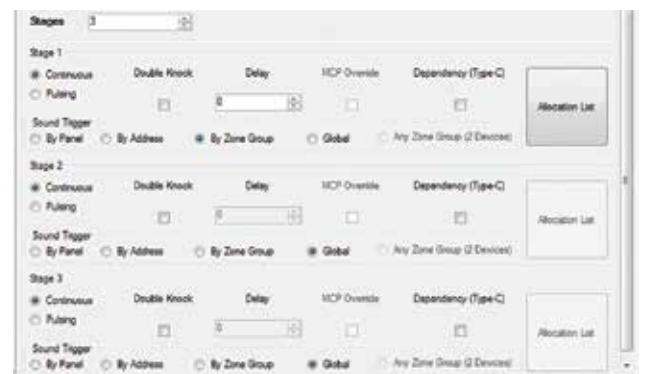

## 4. Fan controller operation

### 4.1. Operation process

#### 4.1.1. Manual/auto key switch

A key switch is provided on the front of the Fan Controller to enable/disable the buttons on the front fascia. This key switch must be kept secure and only accessible by authorised personnel who have been trained to use it or by the Fire Brigade. The purpose of this key switch is to prevent unauthorised activations of fans (i.e. by the general public).

If the system enters a fire condition that effects the cause and effect rules of the fan controller while it is in manual mode it will not activate the fan control outputs but will remember the fire condition. Once the fan controller is back in the auto mode it will activate the fan control outputs as per the fire condition and the cause and effect rules.

#### 4.1.2. Key switch in “manual”

When the fan controller key switch is set in manual mode it enables the Start/Stop buttons for all 6 channels. The fan controller can be placed into manual mode even when the system is in a fire condition. This allows the Customer or the Fire Brigade to manually activate or deactivate the fan associated with each channel of the fan controller.

Pressing the “Start” button will cause the control device for that channel to activate which will turn the fan on. If the fan has no feedback mechanism then the “On” LED will turn on automatically when the “Start” button is pressed. If the fan does have a feedback mechanism then the fan controller will expect to see the on signal from the feedback device within 25s. If the on signal is received within the time limit the “On” LED will turn on and the “Off” LED will turn off, but if the on signal isn’t received then the “Fault” LED will turn on. If the feedback signal arrives after the 25s it will result in the “Fault” LED to turn off, the “On” LED to be turned on and the “Off” LED to turn off to show the current status of the fan.

Pressing the “Stop” button will cause the control device for that channel to deactivate which will turn the fan off. The fan controller expects to see the off signal from the feedback device within 25s. If the off signal is received within the time limit the “Off” LED will turn on and the “On” LED will turn off, but if the off signal isn’t received then the “Fault” LED will turn on. If the feedback signal arrives after the 25s it will result in the “Fault” LED to turn off, the “Off” LED to be turned on and the “On” LED to turn off to show the current status of the fan.

#### 4.1.3. Key switch in “auto”

When the fan controller key switch is set in automatic mode it disables the Start/Stop buttons for all 6 channels will only allow the channels to be activated by the cause and effect programming of the Fire system.

When the Fire system receives a fire alarm signal that effects the cause and effect rules of the Fan Controller it will turn on the “Fire Activation” LED and activate the associated fan as if someone had pressed the start button for that channel (see manual Key Switch in “manual” for more details).

#### 4.1.4. Fault monitoring

If the fan controller receives a fault condition from either the control device or the feedback device (if the fan has feedback) it will result in the “Fault” LED turning on. This also includes short circuit and open circuit conditions between the feedback device and the fan itself.

#### 4.1.5. Reset

A reset from any panel in the Fire system will not reset the Fan Controller itself but may result in the control and feedback devices being reset. This will require the Fan Controller to be manually reset using the “Reset” button. The key switch must be in the manual position in order for the reset button to work.

Pressing the “Reset” button will reset the Fan Control back to its quiescent condition and all output devices will turn off.

#### 4.1.6. Test LED

Pressing the “Test LED” button in auto or manual mode will cause all of the LEDs to flash 3 times and then return to showing the current state of the fan controller channels.

## 5. Basic system layout

### 5.1. FC18 and CFC301 on same panel and loop

Figure 9.

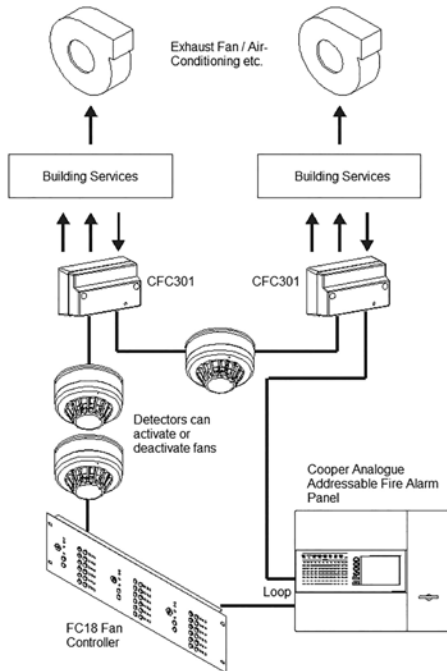

### 5.3. FC18 and CFC301 on different networked panels

Figure 11.

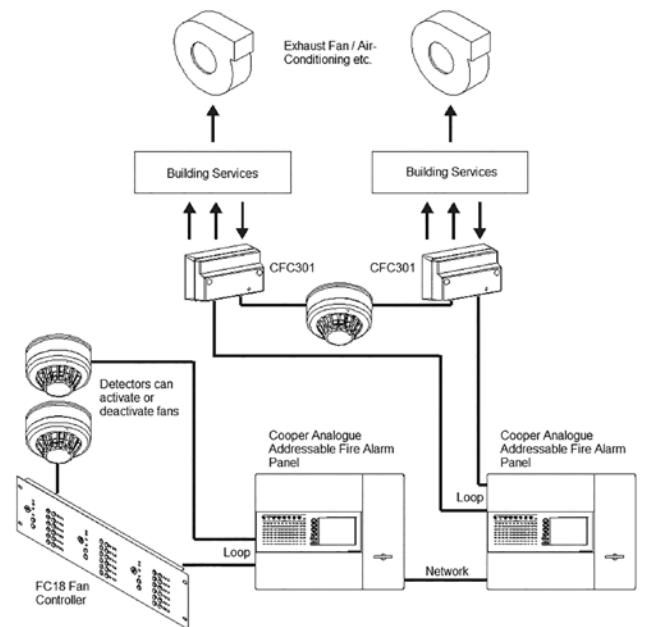

### 5.2. FC6 and CFC301 on same panel but different loops

Figure 10.

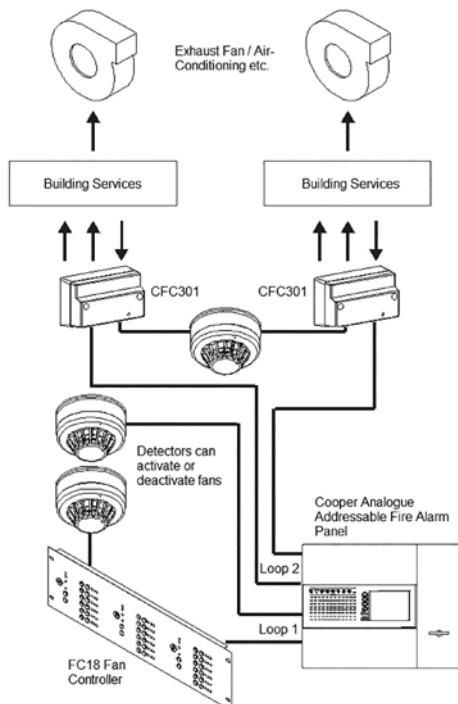

### 5.4. FC6 and MCOM/MCIM on same panel and loop

Figure 12.

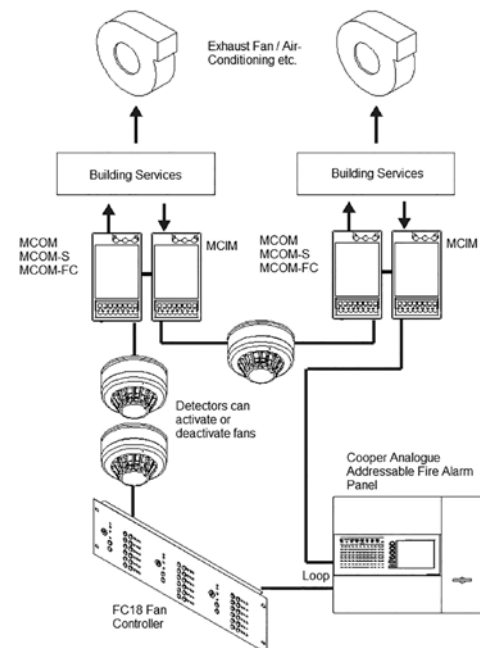

5.5. FC18 and MCOM/MCIM on same panel but different loops

Figure 13.

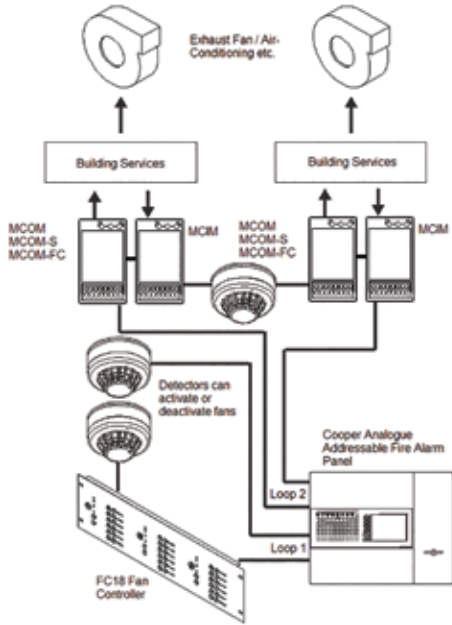

5.6. FC18 and MCOM/MCIM on different networked panels

Figure 14.

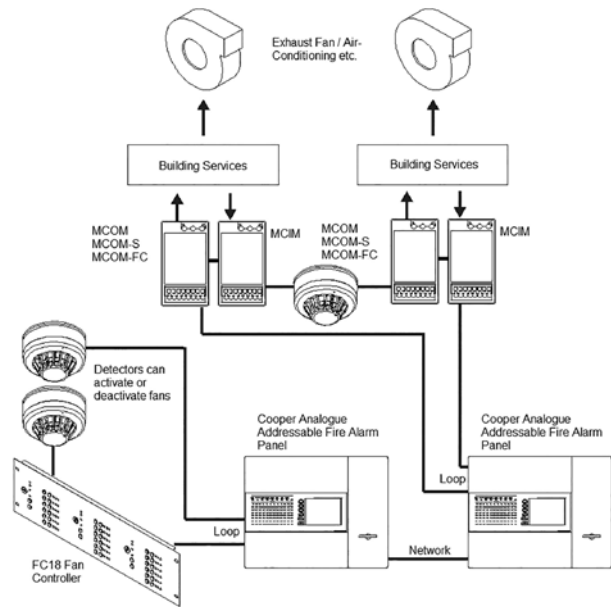



## 6. FC18 specification

### 6.1. Electrical specifications

Loop load	Minimum	Nominal	Maximum
Quiescent current		310µA	
Environmental			
Operating temperature	-10°C		+60°C
Humidity (Non condensing)			95%rh
External 24 volt supply	18v	24v	28v
External current			150mA
Compatibility			
Suitable for use with Cooper analogue addressable fire systems			

### 6.2. Mechanical specifications

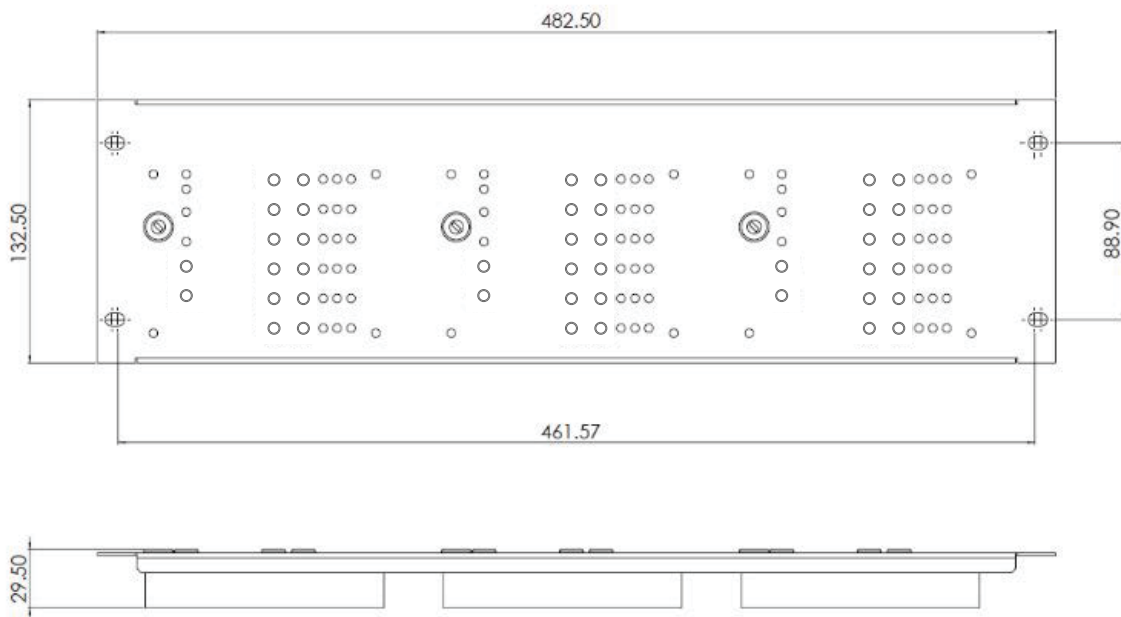

**Eaton**  
EMEA Headquarters  
Route de la Longeraie 7  
1110 Morges, Switzerland  
Eaton.eu

**Eaton**  
Eaton Electrical Systems Ltd.  
Wheatley Hall Road  
Doncaster  
South Yorkshire  
DN2 4NB  
United Kingdom

© 2017 Eaton  
All Rights Reserved  
Printed in UK  
Publication No. PR209-166-505-08 / CSSC-510  
Article No.  
January 2018



Eaton is a registered trademark.

All trademarks are property  
of their respective owners.